

## Product Features

- Designed expressly for wet pipe fire sprinkler systems
- Working pressure rated to 300 psi (20.7 bar)
- Flange and Groove end can be chosen
- Size from 2"-12"
- FM & UL approved

## Technical Features

- Working pressure: 300PSI
- Flange Standard: ASME/ANSI B16.1 Class 125  
ASME/ANSI B16.42 Class 150  
BS EN 1092-2PN16  
GB/T9113.1
- Groove Standard: AWWA C606  
ISO6182-12
- Working Temperature Range: 4~70°C/ 39.2~158°F
- Coating Details: Epoxy coated or coating upon request

## Applications in Fire Protection

This system is applicable to the places with the ambient temperature from 4°C to 70°C. This system is generally installed in the places with fire hazards, like the hotel, shopping mall, hospital, theater, office building, conference center, warehouse, high-rise building and underground garage.

## Product Description

APC wet alarm check valve consists of wet alarm valve, retard chamber, pressure gauges, water motor alarm, pressure switch, drain valve and filter etc.

Alarm Check Valves act as a water flow alarm initiating device in wet pipe sprinkler systems. When waterflows in the sprinkler system due to the operation of one or more automatic fire sprinklers, the alarm valve opens allowing continuous flow of water into the system, which will activate water motor bell and pressure switches.

The design of the Alarm Check Valve allows for installation under both variable and constant supply pressure conditions. The valve trim incorporates a bypass between the water supply and the wet pipe system. When pressure surges in the waters supply occur, the trim allows a small amount of water to bypass the clapper limiting the potential of false alarms.

## Installation

This instrument shall be installed in places where is easy to observe and access. Install The wet alarm valve vertically on the pipes which have been properly tested for its pressure and cleaned. Please note that the arrow for water flow direction is pointing upwards. Reserve enough operation space for repair and maintenance before installation.

Step1: Clean the system pipe network completely before installation. Ensure that the inner wall of the pipes is coated with rust-proof layer and there is no dreg or dirt in the pipes.

Step2: In order to facilitate the observation of the pipe in which an alarm occurs, it is recommended to discharge the water from an open port or have the water discharge state easy to be observed before installation.

Step3: Check whether there is any damage at the joint between the wet alarm valve and the flange, check whether the seal is in good condition and whether the valve disc moves flexibly, carry out the leakage test with a pressure of two times of the rated working pressure. After the test, the valve disc shall be free of leakage; If there is any problem, replace the spare parts or clear the trouble before assembling the parts together.





# Wet Alarm Check Valve

Model: SSBJ-300GG/SSBJ-300FF/SSBJ-300FGA/SSBJ-300FGB

Step4: Turn the pressure gauge to the position where the reading is clearly visible.

Step5: The pressure switch shall be installed on the top of the delayer. This pressure switch must be installed vertically and could only be used indoors. After installation, check if it acts reliably.

Step6: The water motor alarm shall be installed on the top of the delayer, after installation, check if it acts reliably.

Step7: With the exception of support from the trim piping, the ratard chamber will also be binded by a clamp with the piping to avoid any movement or looseness.

## Dimensions

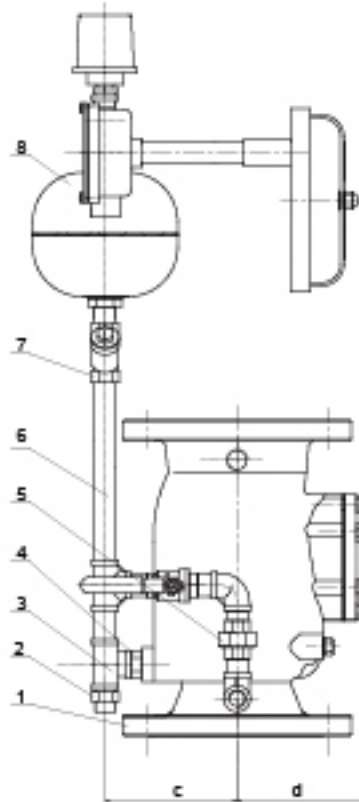

ASSEMBLY DRAWING WITHOUT COMPENSATOR SYSTEM

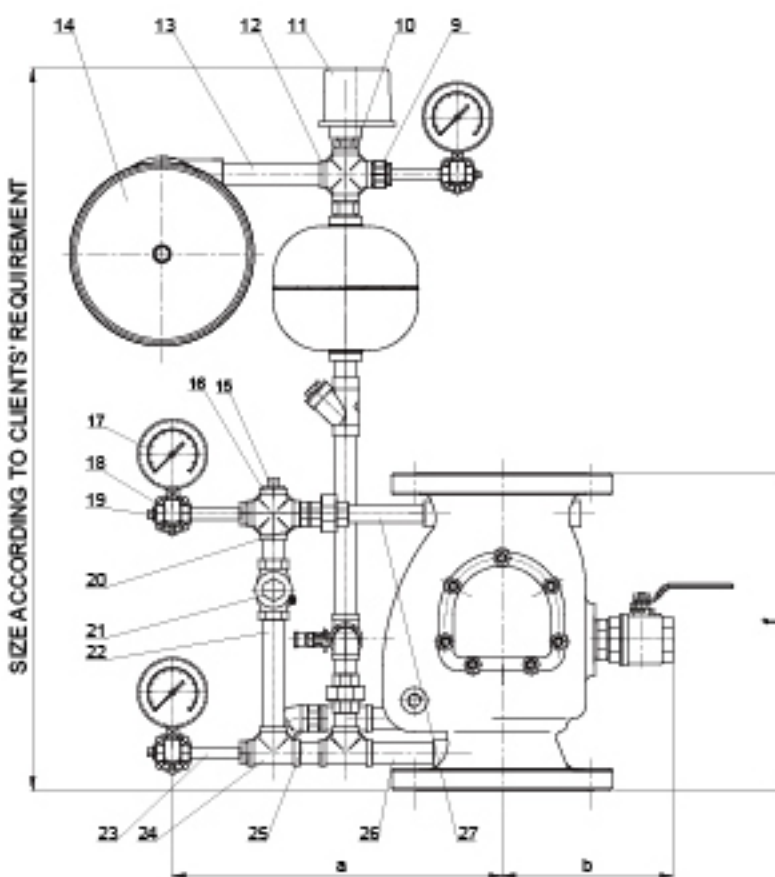

SIZE ACCORDING TO CLIENTS' REQUIREMENT

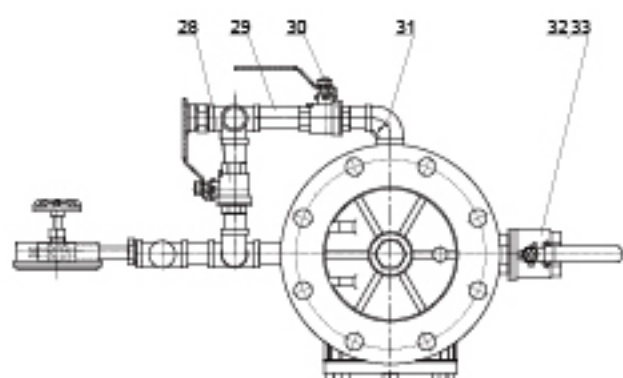

ASSEMBLY DRAWING WITHOUT COMPENSATOR SYSTEM

Size	a	b	c	d
2"	340	205	145	110
2.5"	340	205	145	110
3"	340	205	145	110
4"	342	250	160	136
5"	349	274	180	162
6"	349	274	180	162
8"	415	290	205	195
10"	475	340	240	235
12"	495	368	270	270

No	Name	QTY	Material	Standard
1	Alarm Valve Body	1	Ductile Iron	ASTM A-536 Grade 65-45-12
2	Office, Retard	1	C954	ASTM B148
3	Tee	2	SS304	ASTM A276
4	Nipple	6	SS304	ASTM A276
5	Union	1	SS304	ASTM A276
6	Nipple	1	SS304 / Steel	ASTM A276/1045
7	Y Strainer	1	SS304	ASTM A276
8	Retard Chamber	1	Steel	1045, ASTM 1045
9	Reducer Bushing	1	SS304	ASTM A276
10	Reducer Bushing	1	SS304	ASTM A276
11	Pressure Switch	1	ZSJY1.6BP	Assembly
12	Cross	1	SS304	ASTM A276
13	Nipple	1	SS304 / Steel	ASTM A276/1045, ASTM A29
14	Gong Assembly	1	MH-SLJL-00	Assembly
15	Plug	1	SS304 / C954	ASTM A276/1045, ASTM B148
16	Cross	2	SS304	ASTM A276
17	Pressure Gauge	3	PFE-00A 600SPI	Assembly
18	3-way Valve Gauge	3	C954	ASTM B148
19	Plug	3	Steel/C954	ASTM 1045 A276/B148
20	Orifice, Retard	1	C954	ASTM B148
21	Check Valve	1	SS304	ASTM A276
22	Nipple	1	SS304 / Steel	ASTM A276/1045, ASTM A29
23	Nipple	3	SS304 / Steel	ASTM A276/1045, ASTM A29
24	Tee	2	SS304	ASTM A276
25	Nipple	4	SS304 / Steel	ASTM A276/1045, ASTM A29
26	Nipple	1	SS304 / Steel	ASTM A276/1045, ASTM A29
27	Nipple	1	SS304 / Steel	ASTM A276/1045, ASTM A29
28	Ball Valve	1	SS304	ASTM A276
29	Nipple	1	SS304 / Steel	ASTM A276/1045, ASTM A29
30	Ball Valve	1	SS304	ASTM A276
31	Elbow	2	SS304	ASTM A276
32	Nipple	1	SS304	ASTM A276
33	Ball Valve	1	SS304	ASTM A276

**General Technical Information**

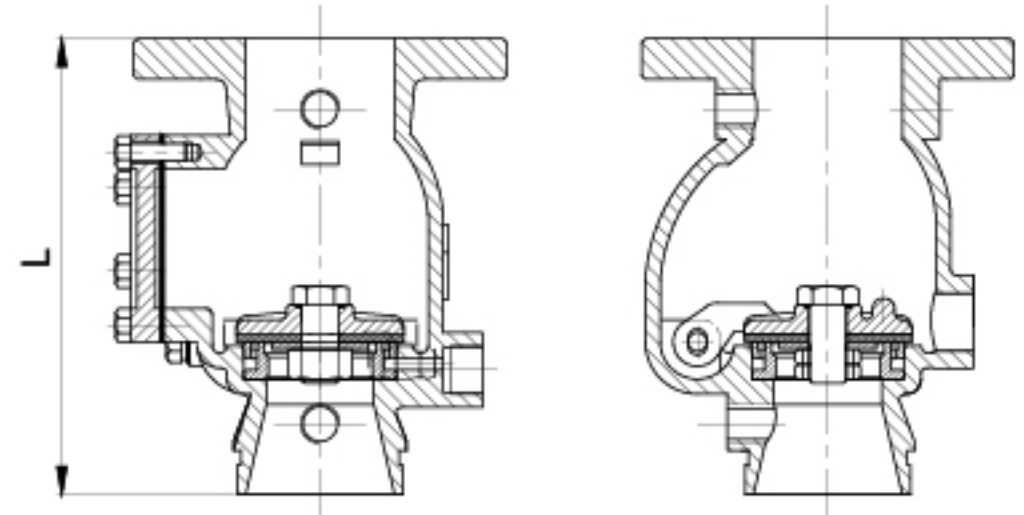
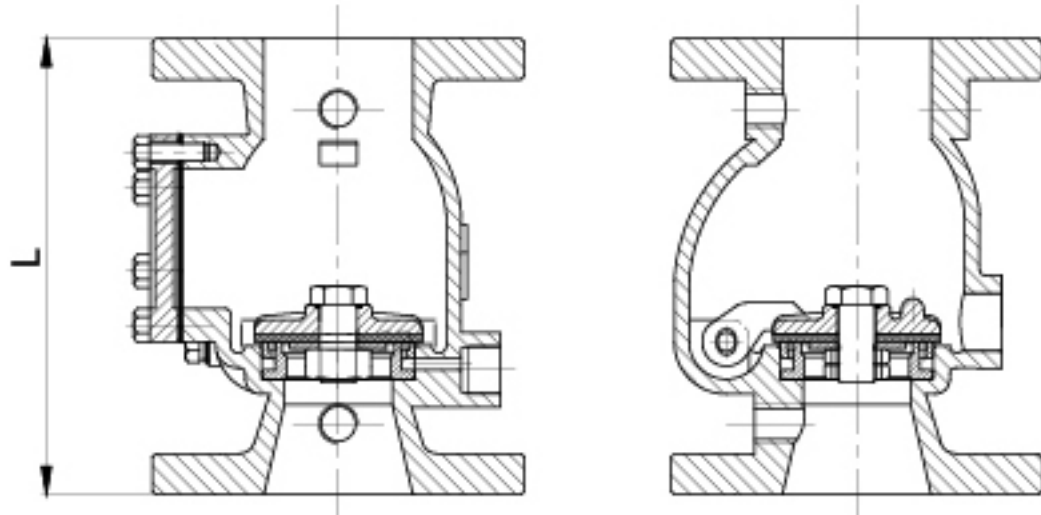

**Flange\*Flange**

**Dimension Chart**

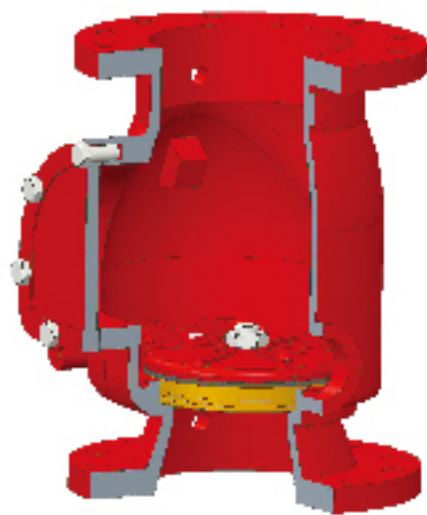

Size	L(mm)	L(inch)
DN50(2in)	233	9.17
DN65(2.5in)	236	9.29
DN80(3in)	245	9.65
DN100(4in)	316	12.44
DN125(5in)	386	15.20
DN150(6in)	390	15.35
DN200(8in)	438	17.24
DN250(10in)	535	21.06
DN300(12in)	622	24.49

Model No. SSBJ-300FF

**Flange\*Groove**

**Dimension Chart**



Size	L(mm)	L(inch)
DN50(2in)	239	9.41
DN65(2.5in)	240	9.45
DN80(3in)	245	9.65
DN100(4in)	316	12.44
DN125(5in)	386	15.20
DN150(6in)	390	15.35
DN200(8in)	438	17.24
DN250(10in)	535	21.06
DN300(12in)	622	24.49

Model No. SSBJ-300FGA

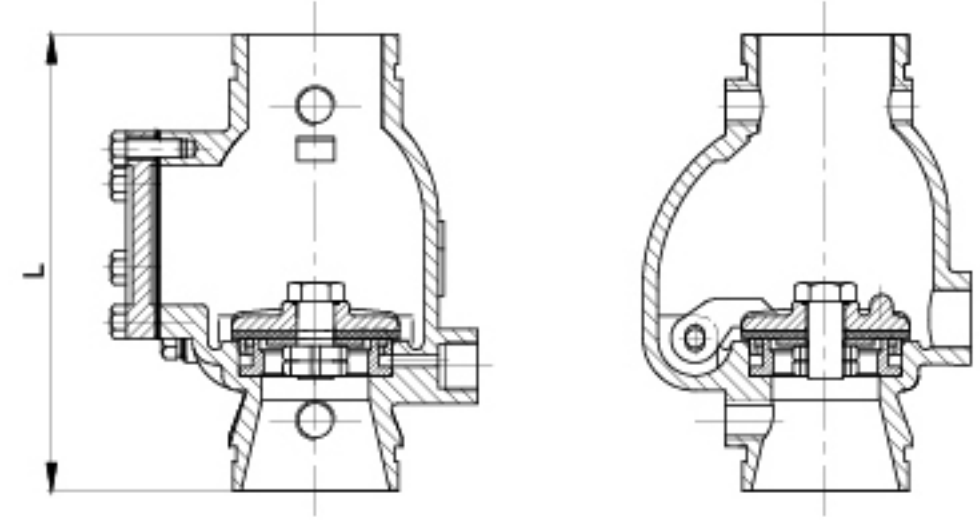
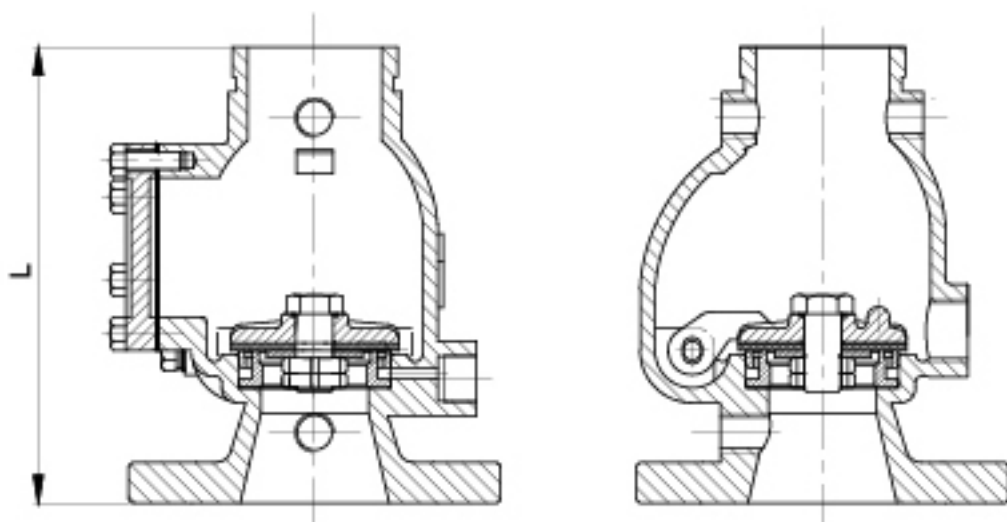

**Groove\*Flange**

**Dimension Chart**

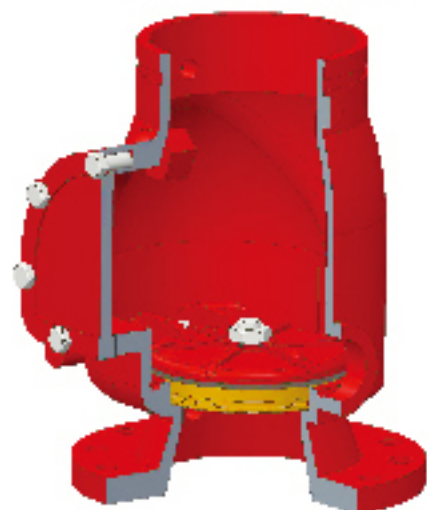

Size	L(mm)	L(inch)
DN50(2in)	239	9.41
DN65(2.5in)	240	9.45
DN80(3in)	245	9.65
DN100(4in)	316	12.44
DN125(5in)	386	15.20
DN150(6in)	390	15.35
DN200(8in)	438	17.24
DN250(10in)	535	21.06
DN300(12in)	622	24.49

Model No. SSBJ-300FGB

**Groove\*Groove**

**Dimension Chart**

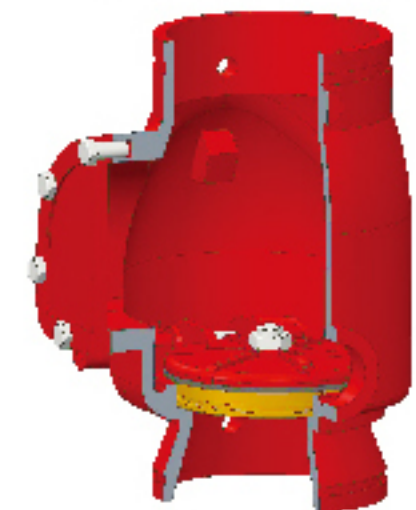

Size	L(mm)	L(inch)
DN50(2in)	245	9.65
DN65(2.5in)	245	9.65
DN80(3in)	245	9.65
DN100(4in)	316	12.44
DN125(5in)	386	15.20
DN150(6in)	390	15.35
DN200(8in)	438	17.24
DN250(10in)	535	21.06
DN300(12in)	622	24.49

Model No. SSBJ-300GG

Wet Alarm Check Valve

Model: SSBJ-300GG/SSBJ-300FF/SSBJ-300FGA/SSBJ-300FGB

Structural Characteristics

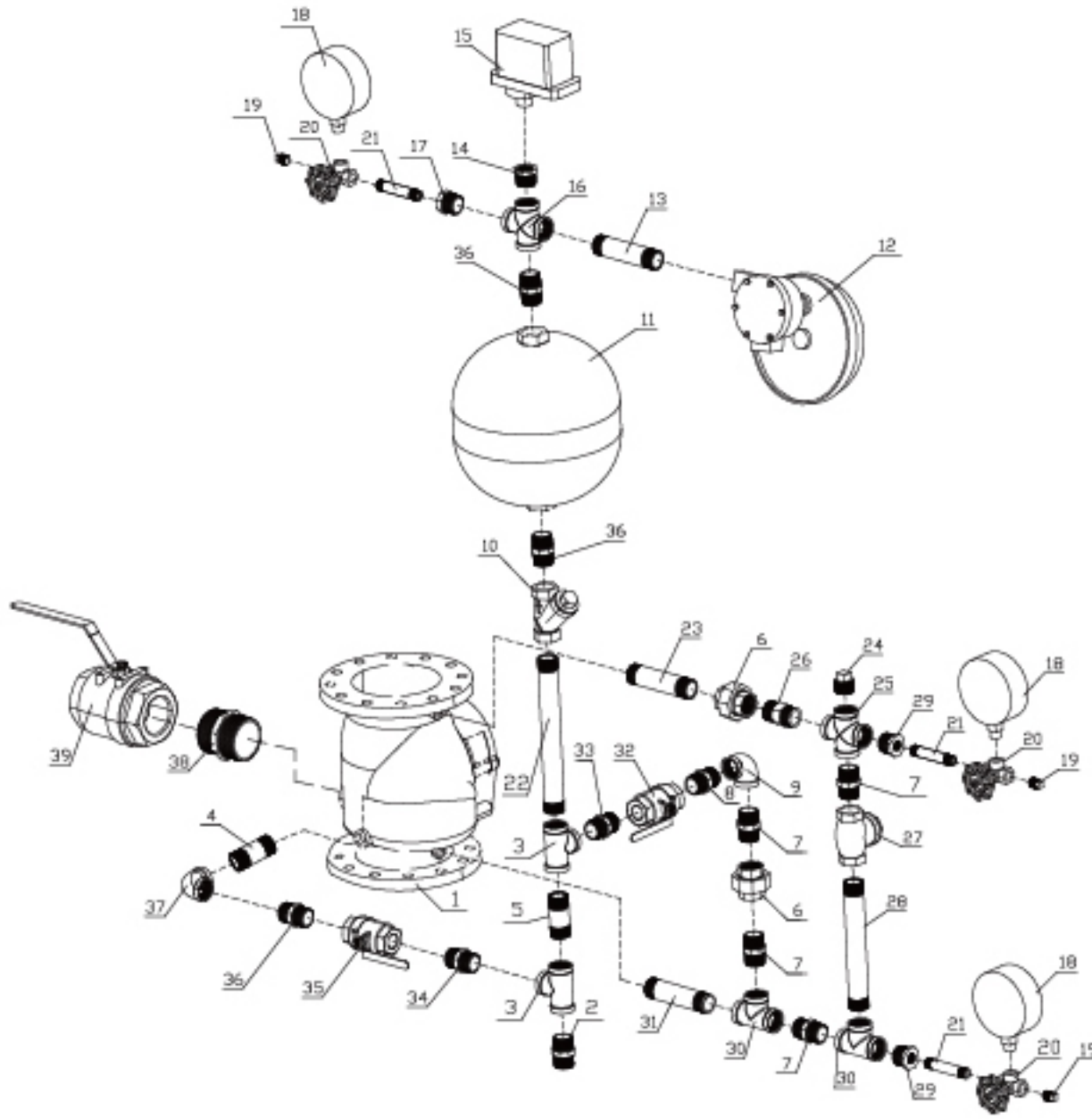

No	Name	QTY	Material
1	Alarm Valve	1	Assembly
2	Orifice Restriction	1	C954
3	Tee	2	SS304/KTH350-10
4	Pipe	1	Galvanized pipe
5	Pipe	2	Galvanized pipe
6	Union	2	SS304/KTH350-10
7	Nipple	4	SS304/KTH350-10
8	Nipple	1	SS304/KTH350-10
9	Elbow	1	SS304/KTH350-10
10	Y Strainer	1	SS304
11	Retard Chamber	1	Assembly
12	Alarm Bell	1	Assembly
13	Pipe	1	Galvanized pipe
14	Nipple	1	SS304/KTH350-10
15	Pressure Switch	1	Assembly
16	Cross	1	SS304/KTH350-10
17	Nipple	1	SS304/KTH350-10
18	Pressure Switch	3	Assembly
19	Plug	3	Galvanized pipe
20	3-Way Valve	3	Assembly
21	Pipe	3	Galvanized pipe
22	Pipe	1	Galvanized pipe
23	Pipe	1	Galvanized pipe
24	Plug	1	C954
25	Cross	1	SS304/KTH350-10
26	Orifice Restriction	1	C954
27	Check Valve	1	Assembly
28	Pipe	1	Galvanized pipe
29	Nipple	2	SS304/KTH350-10
30	Tee	2	SS304/KTH350-10
31	Pipe	1	Galvanized pipe
32	Ball Valve	1	Assembly
33	Nipple	1	SS304/Galvanized pipe
34	Nipple	1	SS304/Galvanized pipe
35	Ball Valve	1	Assembly
36	Nipple	3	SS304/KTH350-10
37	Elbow	1	SS304/KTH350-10
38	Nipple	1	SS304/KTH350-10
39	Ball Valve	1	Assembly

Care and Maintenance

- Clean the dirt and foreign matters attached on the rubber seal surface of the valve disc. Generally, the service life of the rubber seals is no more than eighteen months. Replace the seals in time if they are worn out or aging.
- Clean the dirt and foreign matters from the small holes and seal surface in the groove of the valve disc seals. Be careful not to scratch the surface and keep the small holes unobstructed. If the seal surface can't be repaired, replace it with a new one.
- Clean the blockage in the filter of the alarm valve instrument timely and keep the pipeline unblocked.
- Check and clean the dirt in the delayer, and be sure that the small throttle holes will not be blocked by foreign matters.
- Check the water motor alarm every three months:
  - Step1: Turn on the alarm bell to check whether its sound is loud, immediately remove any trouble if found.
  - Step2: Remove the alarm shell and clear up the dirt and the sediment in the alarm, then reassemble the alarm shell and gaskets in turn.
  - Step3: Remove the leaking joints from the water-wheel and clear up the dirt in it.
- Check the pressure switch periodically (it is recommended to test every three months or more frequently).